

READ ENTIRE INSTRUCTION SHEET BEFORE BEGINNING PROJECT

PARTS LIST

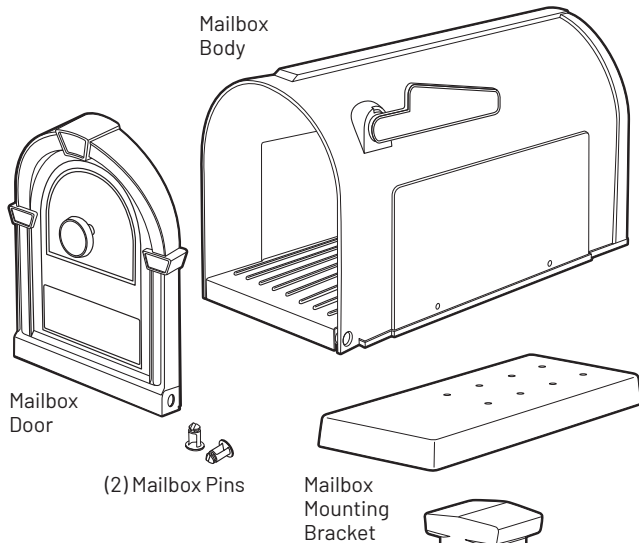

HARDWARE

Shown at actual size

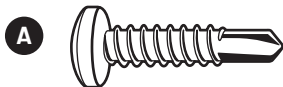

(4) #12 - 1" Pan Head Screws



(4) #6 - 1-1/4" Bugle Head Screws

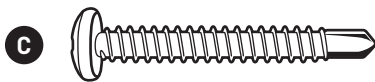

(4) #10 - 1-1/2" Pan Head Screws

NOTE: Customers are required to contact the local post office before installing the mailbox to ensure its correct placement and height at the street. Generally, mailboxes are installed at the height of 41-45 inches from the road surface to inside floor of mailbox or point of mail entry (locked designs) and are set back 6-8 inches from front face of curb or road edge to the mailbox door.

* **PLEASE NOTE:** Concrete may be needed if installing in loose soil

RECOMMENDED TOOLS & SUPPLIES

- POST HOLE DIGGER
- POST LEVEL OR STANDARD LEVEL
- PHILIPS HEAD POWER SCREWDRIVER
- HAMMER / RUBBER MALLET
- PRESSURE TREATED 4" x 4" x 36" WOODEN POST* (Not Included) Actual Diameter of a Standard 4" x 4" Pressure Treated Post: 3-1/2" x 3-1/2"

⚠ WARNING: "Call Before You Dig" – Dial 811.

811 is the designated "call before you dig" phone number that directly connects you to your local One Call center. Each state has different rules and regulations governing digging to insure that buried utility lines will not be disturbed.

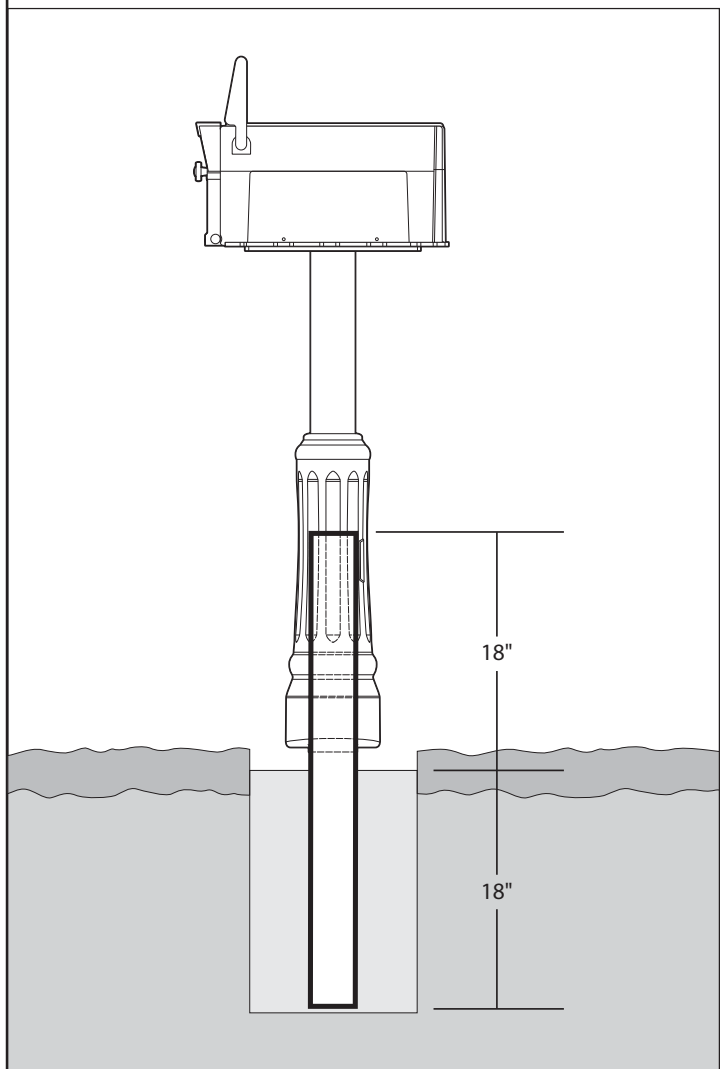

STEP 1 Determine location for mailbox. Using post hole digger, dig a hole 18" in depth. Install treated pine post by burying 18" of the post in the ground - leaving at least 18" of post above ground. Use level to ensure treated pine post is in correct vertical position. Stabilize the treated pine post by firmly tamping down loose soil around post base.

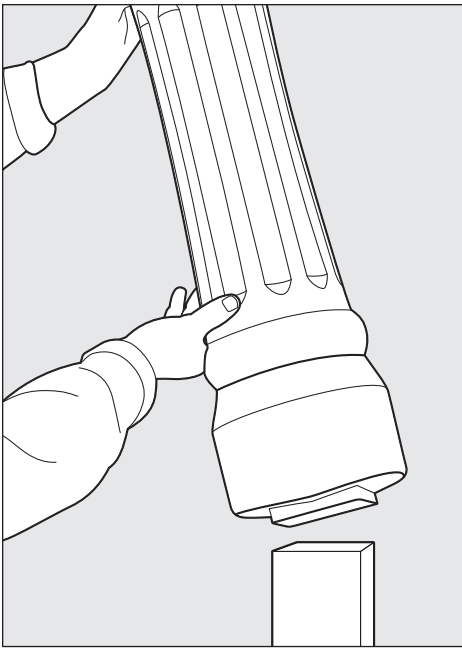

STEP 2 Slide Mailbox Post Sleeve over 4x4 treated pine post.

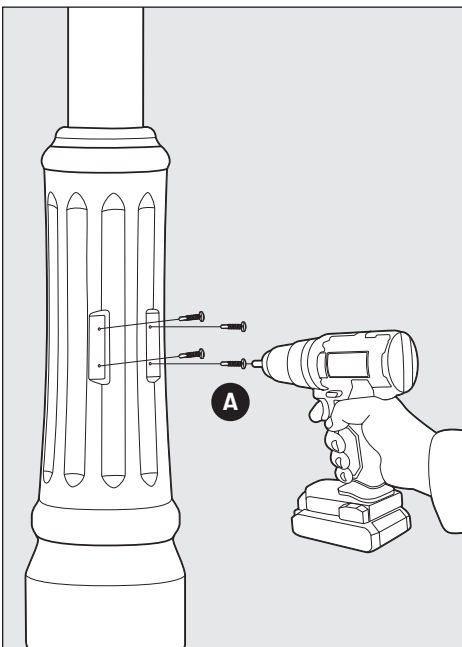

STEP 3 Secure the Mailbox Post Sleeve section to the 4x4 treated pine post using the (4) #12 x 1" Pan Head screws **A** included in the kit.

3 Optional Mounting Positions

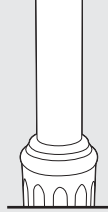
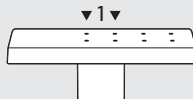

▼2▼

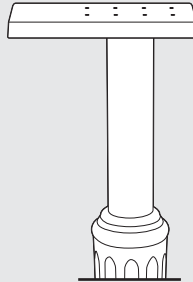

▼3▼

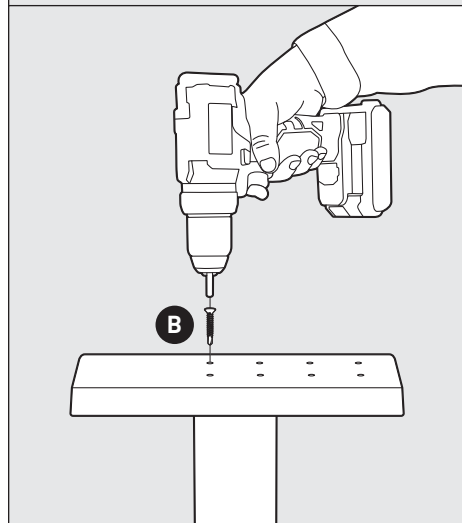
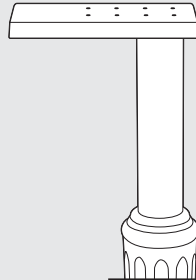

STEP 4 Based on personal preference, mailbox can be mounted in 3 optional positions shown above. Attach Mounting Bracket to top of Mailbox Post Sleeve using the (4) #6 x 1-1/4" Bugle Head screws **B** secure the Mounting Bracket to the Post Sleeve. Do not over tighten screws.

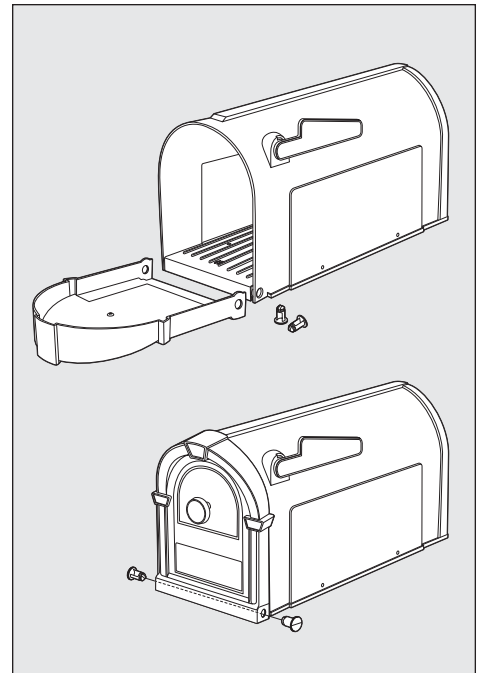

STEP 5 Assemble your mailbox by using (2) pins to attach Mailbox Door to holes in Mailbox Body. Pins can be snapped into place by pressing firmly with thumb or tapped in using a rubber mallet.
TIP: Make sure the pins are fully snapped into place. If they are installed correctly, you will not be able to remove the pins with your fingers.
TIP: Holes in door will be positioned outside of holes on mailbox body before insertion of pins.

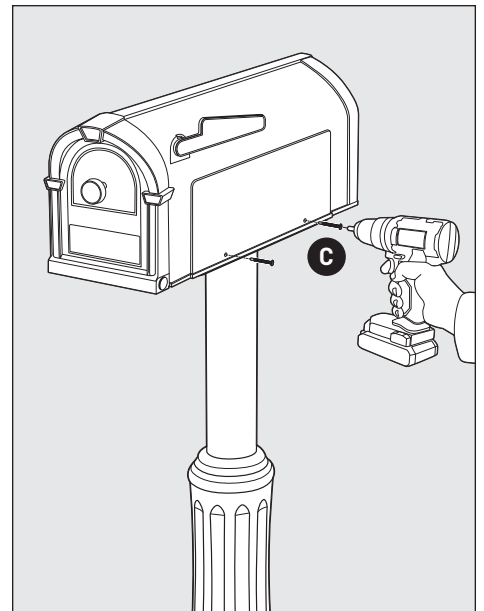

STEP 6 Place Mailbox on to top of Mailbox Post Bracket and secure with (4) 10 x 1-1/2" Pan Head screws. **C** Screws will self tap into bracket.



Postal Pro is a Creative Solutions, LLC Product
Manufactured in Purvis, MS

Customer Service 877-544-5220
customerservice@creativesolutionscp.com
www.postalpromailboxes.com

05/22